

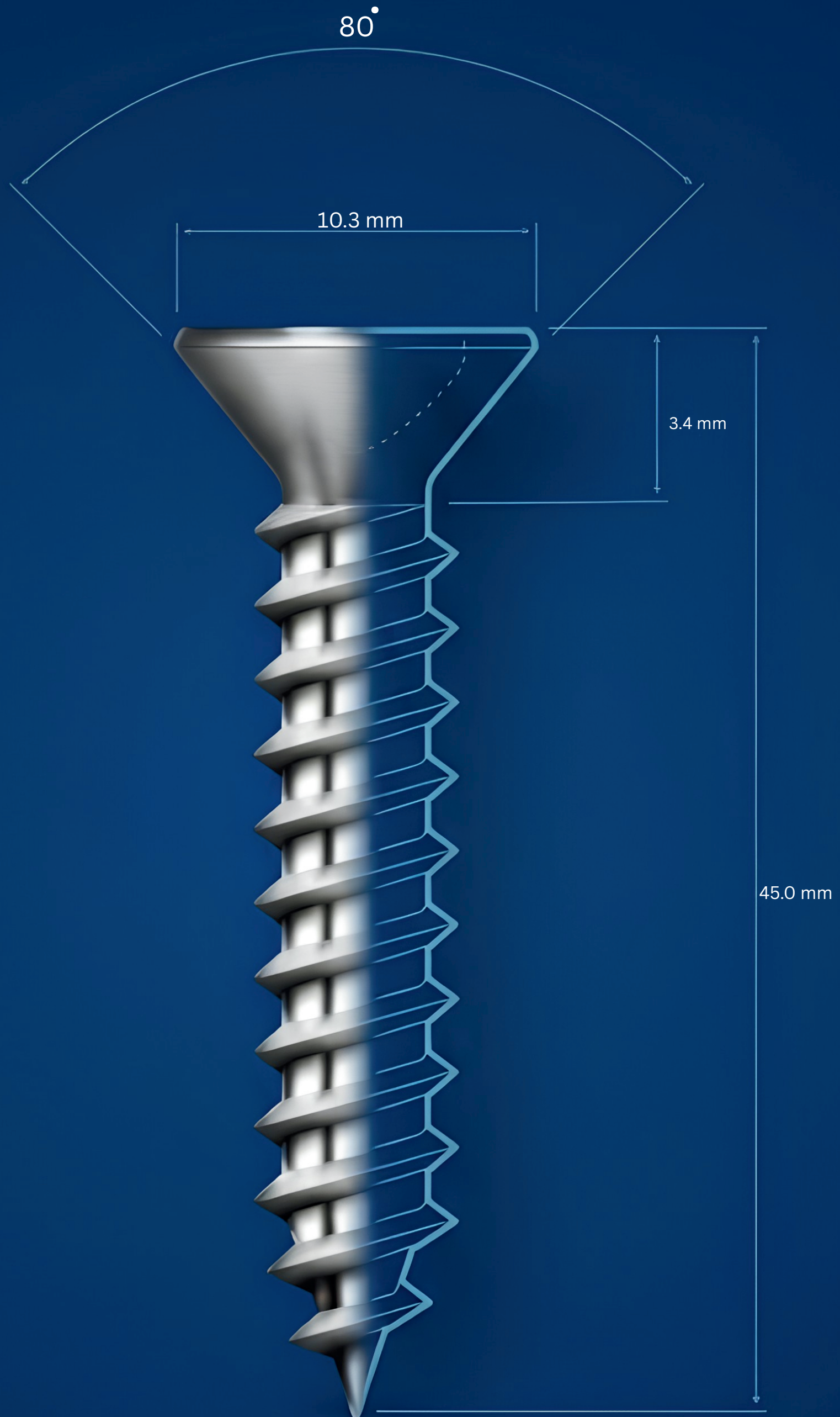

TAPPING SCREWS





Chipboard Screws

Flat head

Pozi Recess

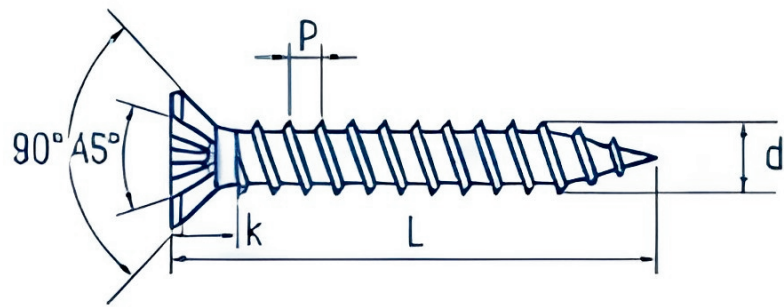

POZI DRIVE (Z)



d	dk (max)	k	x	p
M4	7.9	4.25	2	1.80
M4.5	8.9	4.60	2	2.0
M5	9.9	5.20	2	2.2
M6	11.9	6.00	3	2.80

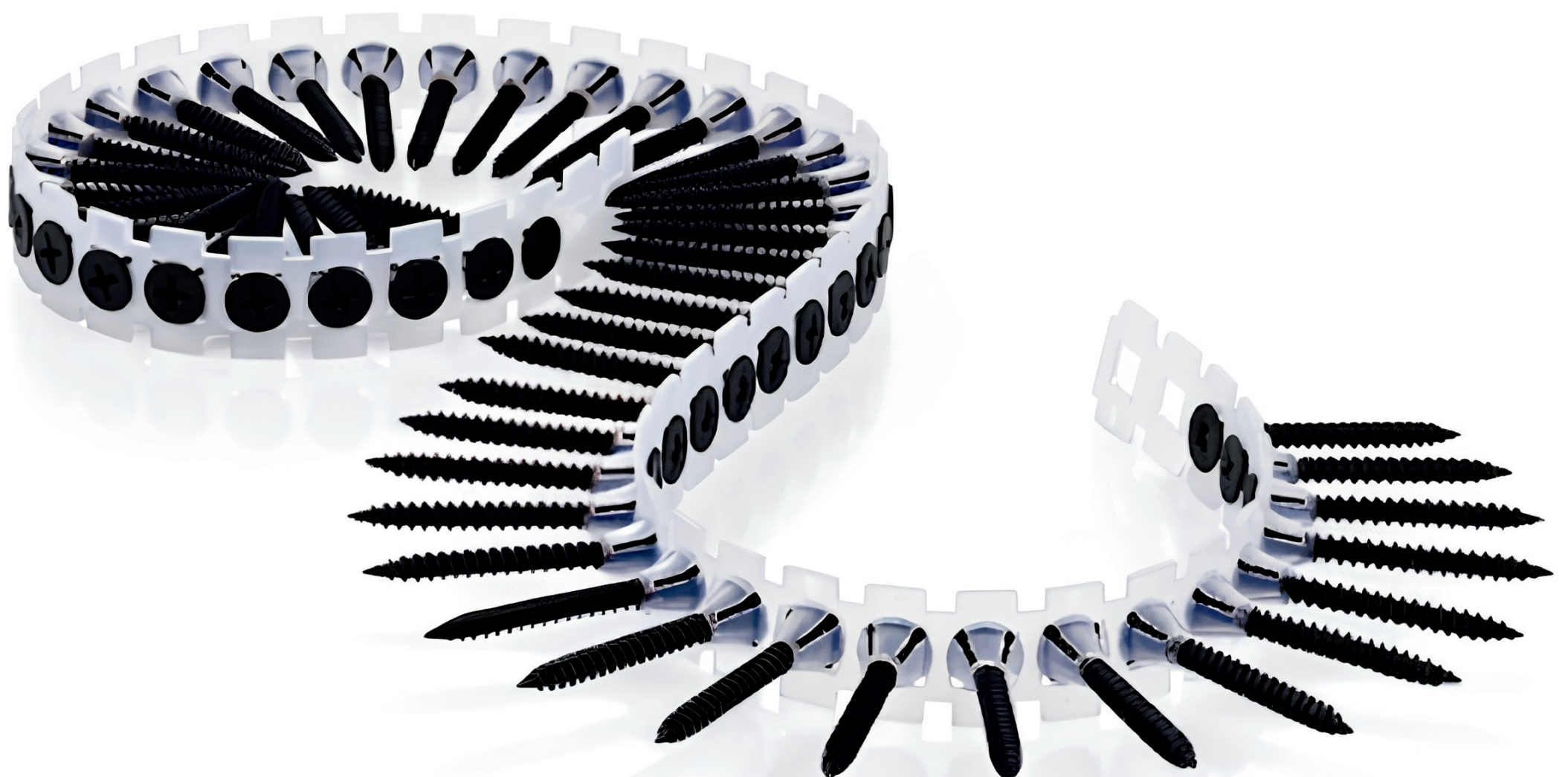



Phillips Bugle Head

Twinfast thread

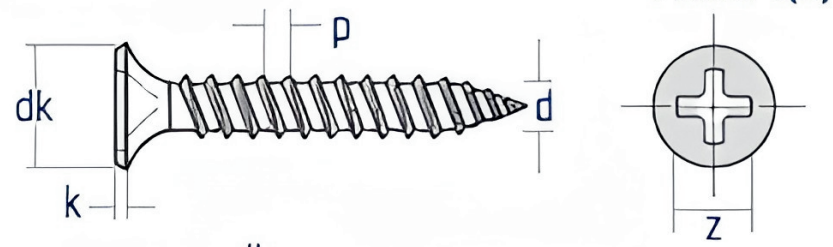

PHILLIPS(H)

d	dk (max)	k	z	p
M3.5	8-8.4	0.8	No.2	1.49
M3.9	8-8.4	0.8	No.2	1.59
M4.2	8-8.4	0.8	No.2	1.69
M4.8	8.8-9.2	0.8	No.2	2.12



Coarse thread

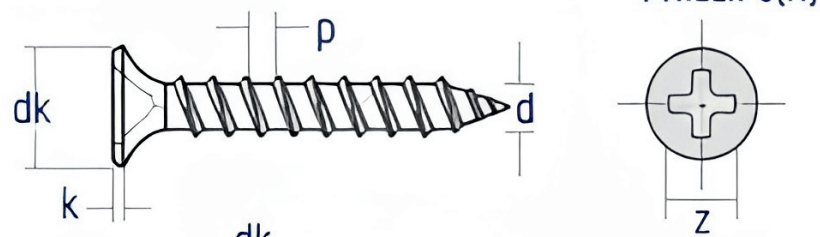

PHILLIPS(H)

d	dk (max)	k	z	p
M3.5	8-8.4	0.8	No.2	2.82
M3.9	8-8.4	0.8	No.2	2.82
M4.2	8-8.4	0.8	No.2	3.18
M4.8	8.8-9.2	0.8	No.2	3.18



Size (mm)

3.5x	3.9x	4.2x	4.8x
19	25	32	38
25	25	38	50
25	35	50	75
32	38	63	90
35	41	75	100
38	45	80	110
41	50	90	

Size (inch)

#6x	#7x	#8x	#10x
3/4"	1"	1-1/4"	1-1/2"
1"	1-1/4"	1-1/2"	2"
1-1/4"	1-3/8"	2"	3"
1-1/4"	1-1/2"	2-1/2"	3-1/2"
1-3/8"	1-5/8"	3"	4"
1-1/2"	1-3/4"	3-5/32"	4-5/16"
1-5/8"	2"	3-1/2"	



DIN 7981 Tapping Screw Pan Head

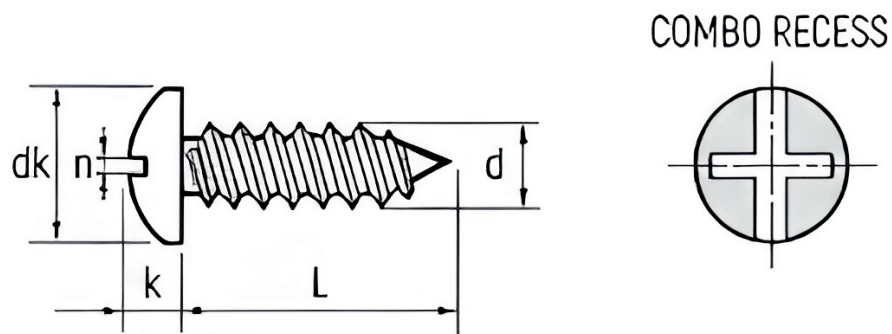

d	dk (max)	k	n (min)
M2.9	5.6	1.50 - 1.75	0.86
M3.5	6.9	1.85 - 2.10	1.06
M3.9	7.5	2.00 - 2.45	10.6
M4.2	8.2	2.15 - 2.45	1.26
M4.8	9.5	2.50 - 2.80	1.26
M5.5	10.8	2.85 - 3.20	1.66
M6.3	12.5	3.30 - 3.65	1.66

Size (mm)												
	6.5	9.5	9.5	9.5	9.5	9.5	16	19				
	9.5	13	16	16	13	13	19	25				
	13	16	16	16	16	16	25	32				
2.9 _x	16	3.5 _x	19	3.9 _x	16	4.2 _x	19	4.8 _x	19	5.5 _x	6.3 _x	38
	19		25		25		25		25			45
	—	—	—	—	32	—	32	—	32	45	—	50
							38			50		75

Size (inch)												
	1/4"	3/8"	3/8"	3/8"	3/8"	3/8"	5/8"	3/4"				
	3/8"	1/2"	1/2"	1/2"	1/2"	1/2"	3/4"	1"				
	1/2"	5/8"	5/8"	5/8"	5/8"	5/8"	1"	1-1/4"			1-1/4"	
#4 _x	5/8"	#6 _x	5/4"	#7 _x	3/4"	#8 _x	3/4"	#10 _x	3/4"	#12 _x	#14 _x	1-1/2"
	3/4"		1"		1"		1"		1"			1-3/4"
	—	—	—	—	1-1/4"	—	1-1/4"	—	1-1/4"	1-3/4"	—	2"
							1-1/2"			2"		3"



DIN 7982 Tapping Screw Flat Head

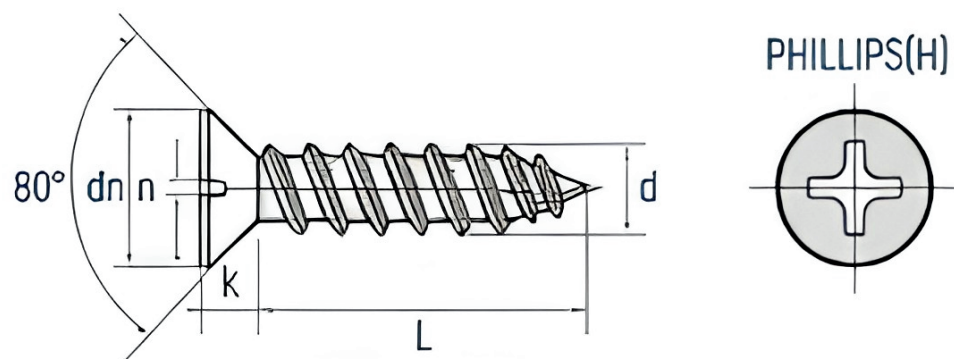

d	dk (max)	k	H
M2.9	2.20 - 2.50	1.7	1
M3.5	6.44 - 6.80	2.1	2
M3.9	7.14 - 7.50	2.3	2
M4.2	7.74 - 8.10	2.5	2
M4.8	9.14 - 9.50	3.0	2
M5.5	10.37 - 10.80	3.4	3
M6.3	11.97 - 12.40	3.8	3

Size
(mm)

	6.5	9.5	9.5	8.5	9.5	16	19						
	9.5	13	13	13	13	19	25						
	13	16	15	16	16	25	32						
2.9x	16	3.5x	19	3.9x	19	4.2x	19	4.8x	18	5.5x	32	6.3x	38
	19		25		25		25		25		38		45
	—	—	—	—	32	—	32	—	32	—	45	—	50
									38		50		75

Size
(inch)

	1/4"	3/8"	3/8"	3/8"	3/8"	5/8"	3/4"						
	3/8"	1/2"	1/2"	1/2"	1/2"	3/4"	1"						
	1/2"	5/8"	5/8"	5/8"	5/8"	1"	1-1/4"						
#4x	5/8"	#6x	3/4"	#7x	3/4"	#8x	3/4"	#10x	3/4"	#12x	1-1/4"	#14x	1-1/2"
	3/4"		1"		1"		1"		1"		1-1/2"		1-3/4"
	—	—	—	—	1-1/4"	—	1-1/4"	—	1-1/4"	—	1-3/4"	—	2"
									1-1/2"		2"		3"



DIN 7983 Tapping Screw

Oval Head (Phillips or Pozi Recess)

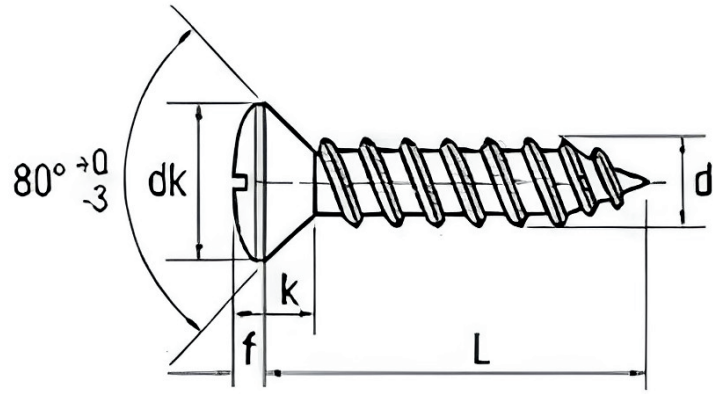

PHILLIPS(H)

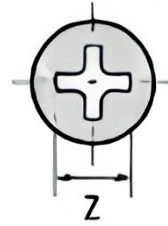

POZI ORIVEI(Z)

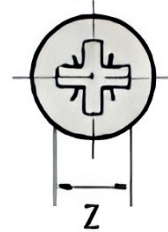

d	dk (max)	k	f	z
M2.9	5.20-5.50	1.7	0.9	1
M3.5	6.44-6.80	2.1	1.2	2
M3.9	7.14-7.50	2.3	1.3	2
M4.2	7.74-8.10	2.5	1.4	2
M4.8	9.14-9.50	3.0	1.5	2
M5.5	10.37-10.80	3.4	1.7	3
M6.3	11.97-12.40	3.8	2.0	3

Size (mm)

6.5		9.5		9.5		9.5		9.5		16		19	
9.5		13		13		13		13		19		25	
13		13		16		16		13		25		32	
M2.9x	16	3.5x	19	3.9x	19	4.2x	19	4.8x	19	5.5x	32	6.3x	38
19		25		25		25		25		38		45	
—		—		—		32		32		45		50	
—		—		—		—		38		50		75	

Size (inch)

1/4"		3/8"		3/8"		3/8"		3/8"		5/8"		3/4"	
3/8"		1/2"		1/2"		1/2"		1/2"		3/4"		1"	
1/2"		5/8"		5/8"		5/8"		5/8"		1"		1-1/4"	
#4x	5/8"	#6x	3/4"	#7x	3/4"	#8x	3/4"	#10x	3/4"	#12x	1-1/4"	#14x	1-1/2"
3/4"		1"		1"		1"		1"		1-1/2"		1-3/4"	
—		—		—		1-1/4"		1-1/4"		1-3/4"		2"	
—		—		—		—		1-1/2"		2"		3"	



Hex Washer Head



Size [mm]			Size [inch]		
	16		16	5/8"	5/8"
	19		19	3/4"	3/4"
	25		25	1"	1"
	32		32	1-1/4"	1-1/4"
5.5 x	38	6.3 x	38	#12 x	1-1/2"
	50		45		2"
	63		50		2-1/2"
	75		63		3"
	90		75		3-1/2"
				#14 x	1-1/2"
					1-3/4"
					2"
					2-1/2"
					3"



Hex, Phillips or Torx Recess Confirmat Screw

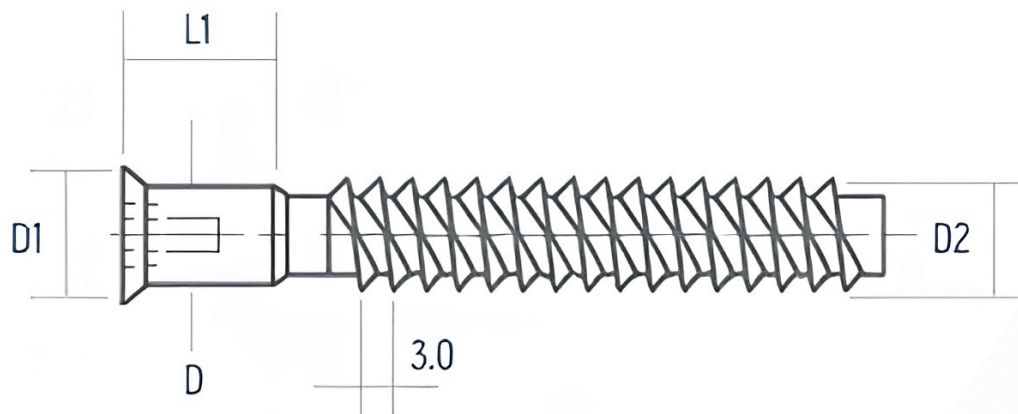

d	L	L1	D1	D2
6.3	40	10-12	9.5-10.5	6.0-6.4
6.3	50	10-12	9.5-10.5	6.0-8.4
7.0	40	10-12	9.5-10.5	6.7-7.1
7.0	50	10-12	9.5-10.5	
7.0	60	10-12	9.5-10.5	
7.0	70	10-12	9.5-10.5	

Chipboard Thread pitch 3.0
Standard deep thread pitch 2.6



info.screwworld@gmail.com

+91-9500168319

Godown No.3 , 73/2B1, Chettipadu Road,
Mevalurkuppam Village 55 -Thandalam PO,
Taluk, Tamil Nadu 602105.

